

Development of a tracking system for parabolic solar concentrators

Dr. Kareem K. Jasim
Energy and fuel research center
University of technology

Summary:

This research includes the development of a self-tracking system for solar concentrators which can increase the gained solar energy.

This system is specified by using the generated power from the solar cells to feed the tracking system directly. In other words the electrical power needed is self generated. Therefore, this system can be used in agricultural places in our country.

The other side of the work in this research is using advanced technique for tracking the solar collectors. The design combines a Field Programmable processor with two-axis motor tracking controller to integrate such as microprocessor, memory, and input/output into one Altera Field Programmable based on system-on-programmable-chip concepts.

1.INTRODUCTION:

Reflecting materials are used to collect sun light. These materials work to collect and concentrate sun light towards the focus at which the absorber surface exists where the thermal process happen.

One of these concentrators is the parabolic cylindrical concentrator which works to concentrate the falling sun light when the line passing through the focus, sun rays and the main line of the reflecting surface(vertex line) in the same level. In order to get this focus falling the solar center must be rotated around its self in the direction of the Azimuth angle all the day tracking the sun in its movement. This aim can be done by two ways first by hand which is an old method for tracking and it is not practical. The second tracking method which is the mechanical way. This is method either hydraulic or automatic.

This research leads to use the automatic electrical tracking and control system as shown in Fig.(1). Also to supply electrical power from sun light. [1]

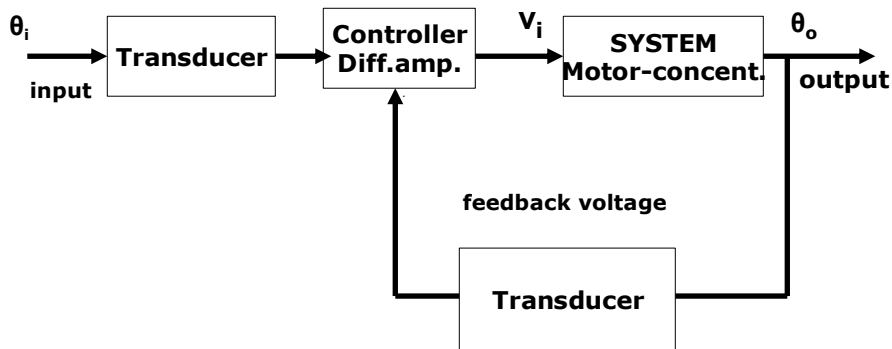

Fig.(1) Control System

The control system consists of dynamic system which works in a certain way without human interfere all the time (automatically). The main parts of this system are:

- 1.The system: this unit that needed to be controlled (in this research the solar concentrators and the electrical motor are to be controlled).
- 2.Transducers: these units works to convert the power from one form to another form(in our research the solar and the light cells are used to work as transducers).
- 3.The controller: this unit work as the heart of the system to find the angular error between the sun concentrator and the sun light which also determines the solar energy to be converted via the process. [1]

1.1 Solar Concentrators:

This solar system which can be built consists of five (or more) solar concentrators in the shape of parabolic cylindrical designed and made of available materials(painted aluminum and wood). The weight of each concentrator in the range of 14 kg aligned in horizontal line.

In order to get as much as possible of the solar energy the concentrators must be directed towards the south with an angle of 30 above the horizontal. This can be done by fixing them on a steel frame above ground.

The absorbing surfaces of the collectors are connected together in parallel and from the other side connected to a water tank across an electrical pump. The function of the pump is to rotate the water through the absorbers.

1.2 Automated control and tracking system:

The tracking system consists of electrical system which operates to detect the sun location with respect to the solar collector, and calculation of angular error between the sun location and the solar concentrator location. According to this the required torque needed to turn the solar concentrator, and the mechanical system which works to convert this torque to a slow motion of the solar concentrator, in order to turn it towards the sun light. [2]

2.PRACTICAL DESGIN:

2.1 The Electrical System:

This system consists of many units connected with each other as shown in Fig.(2).

The main idea of the system operation is to direct the solar concentrators towards the sun light, depending on the detection and calculation of the deviation angle of the solar concentrators $\theta_d(t)$, and the sun location angle $\theta_i(t)$, that's after changing it into electrical quantities using two photo cells connected as shown in Fig.(3). This cell works to close the circuit when the sun light exists and open it when there is no sun light.

The cells are placed on a base separated by a wall in such away to prevent the sun light from arriving to one cell when the sun rays is not vertical.

When the sun rays are vertical on the solar concentrator the separated wall is directed towards the sun to let the sun rays reaching both photo cells surfaces. In this case both photo cells are active. [3]

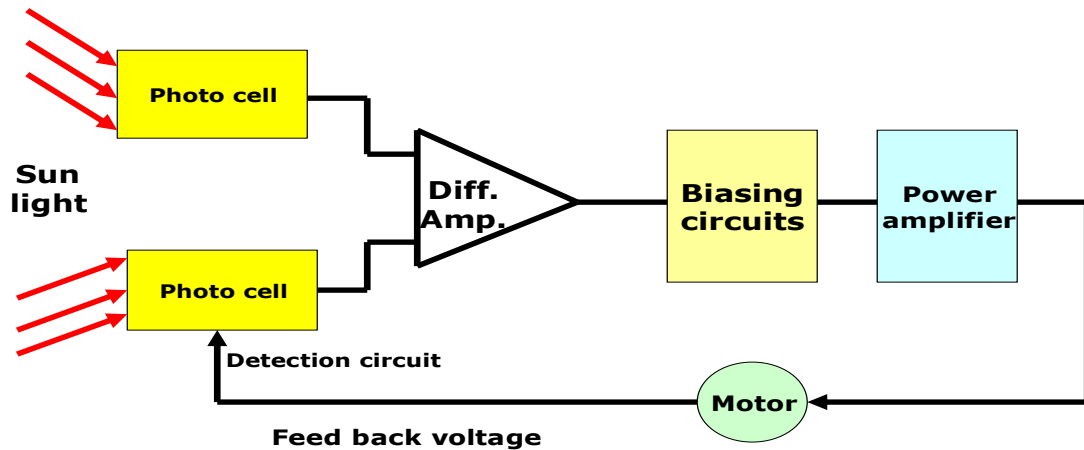

Block diagram of tracking and control system

Fig.(2) Electrical system block diagram

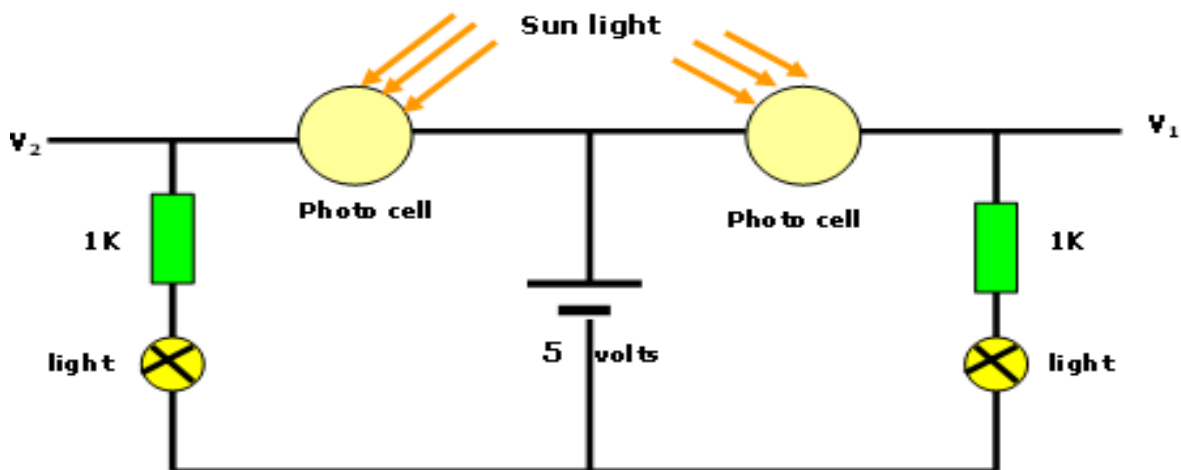
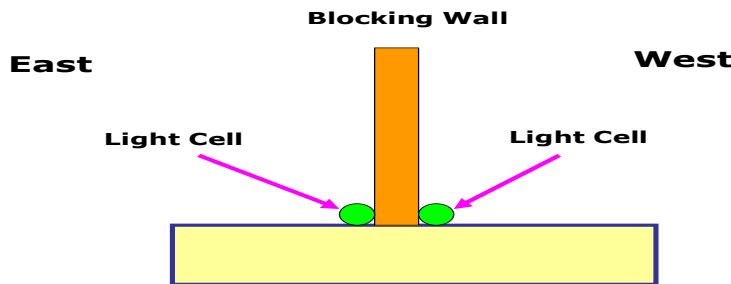

Fig.(3) Circuit diagram of photo cells.

The separated wall can be designed in such way every cell is sensitive to an angle of one degree as shown in Fig.(4) below.

The detection circuit generates two electrical signals one of them considered as a reference voltage varies with the direction of sun light, and the other considered as reverse supply voltage varies with direction of solar concentrator. These signals are supplied to the error signal circuit. [4]



Blocking Wall and Light Cells Positions

Fig.(4) Separated wall

2.2 Error generated signal circuit:

This circuit compares between the electrical signals which are fed to it from the detection circuit and generate the error signal (value and direction), then amplifies this signal to a value operates the next unit(8 volts). The error voltage of one degree in the sun deviation equals to (0.6)volts, therefore the gain of the error signal generator is (14).

The electrical circuit of the error signal generator is shown in Fig.(5).

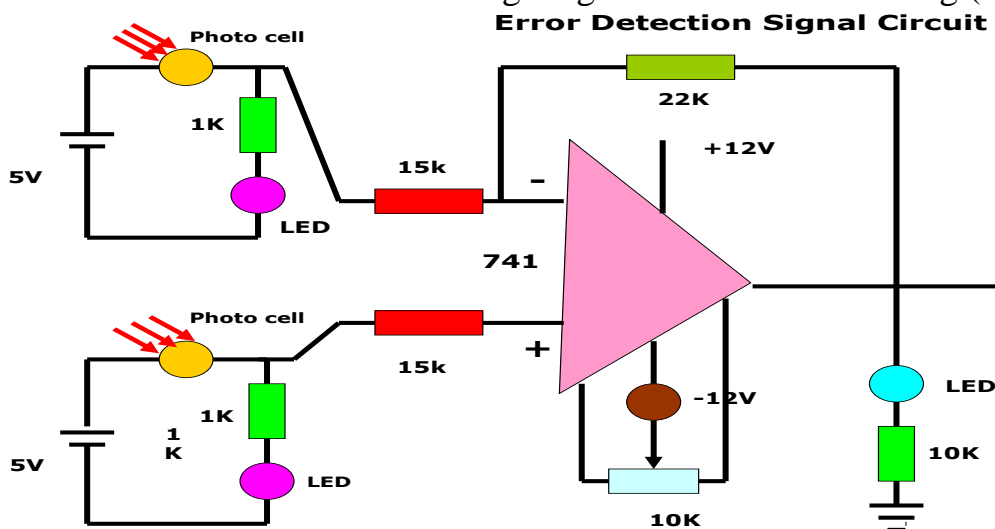

Fig.(5) Error signal circuit

2.3 The Driving Circuit:

The driving circuit is used to control the opening and closing of the relays which used in the power amplifier. There are four relays are controlled to be opened and closed according to the error signal as shown in Fig.(6).

When the error signal is positive , the transistor TR1 is in a saturation state(ON) and transistor TR2 is a cut off state(OFF)which operates to close the relay S2S1. When the error signal is negative, the transistor TR2 is (ON) and TR1 is (OFF) which operates to close the relay S4S3. [5]

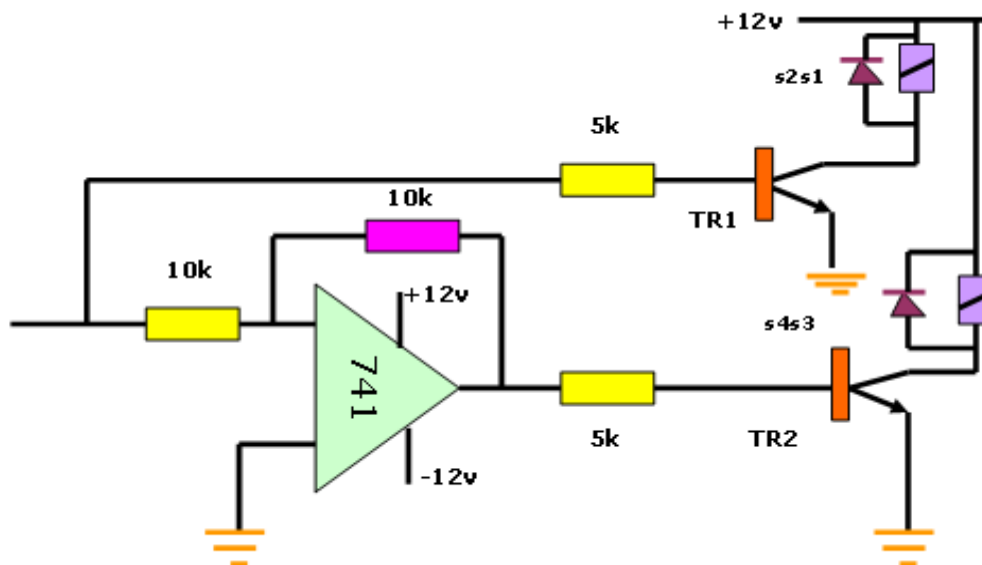

Fig.(6) The Driving Circuit.

2.4 The power amplifier:

In order to control the movement of the solar concentrator in such away to track the sun rays we have to control the motor movement in both directions. Therefore , four relays are used connected as shown in Fig.(7) to control the amount of electrical energy supplied to the motor and its direction. For turn the motor in the positive direction , the relay S2S1 are closed and the relay S4S3 is opened and vice versa.

The diodes(D₄,D₁) are used protect the relays during the opening and closing to prevent spark occurrence across the relays.

The previous electrical circuits work to direct the solar system towards the sun, then tracking the sun from sunset until the sun reset.

In the evening the solar concentrator is directed towards the sun reset.

In this case the error signal equals to zero because both photo cells are reactive therefore the solar system is stopped. During the sunset next day the solar concentrators are stopped towards the other end(sun reset) so that they must be returned towards the sunset. For this reason a light

Power Amplifier and Tracking Circuit

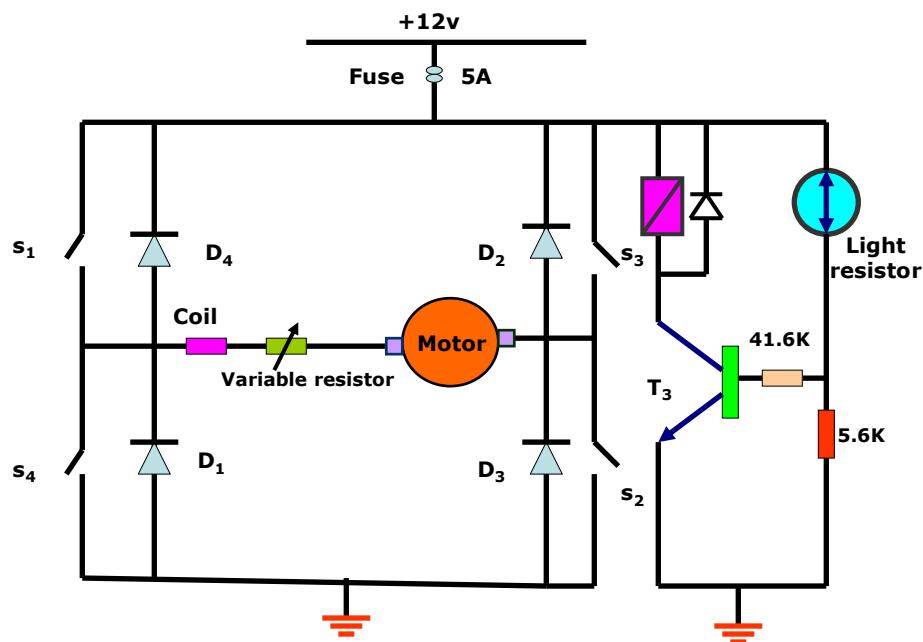

Fig.(7) power amplifier and tracking circuit

Resistor fixed behind the light cells and connected to the circuit as shown in Fig.(7). This resistor works to close and opens the relay S4S3 to return the solar system automatically the sunset position to enable the detection circuit to operate and in this case the light resistor is reactive because it lies in the shadow place which does not affect the operation of the detection circuit. [6]

2.5 The Electrical Motor:

The electrical motor used is a d.c. motor operated by d.c. voltage (12v) and unloaded speed of 45 r.p.m , 100 kg.cm torque.

2.6 Control of the pump operation:

In the solar water heaters the electrical pump force the water to flow through the system. When the temperature of water in the absorbed surface is lower than the tank water temperature for any reason the water pump must set to OFF to stop the water flow to the solar collector in order to reserve the temperature of the tank water when attach the absorbed surface. Therefore, two thermistors (sensors) ,one of them fixed at the solar collector output to indicate to the collected temperature and the other attached at the output of the water tank to indicate the tank water temperature. These two thermistors are connected as shown in fig.(8), to control closing and opening the relay which connects the water pump to the electrical supply when there is a temperature difference of one degree between the collector and the output water from the tank.

When the temperature of the thermistor at the output of the collector is higher than the thermistor temperature at the bottom of the tank. In the opposite case the relay works to stop the water pump.

The electrical pump depends on the difference between the temperatures of the thermistors.[7]

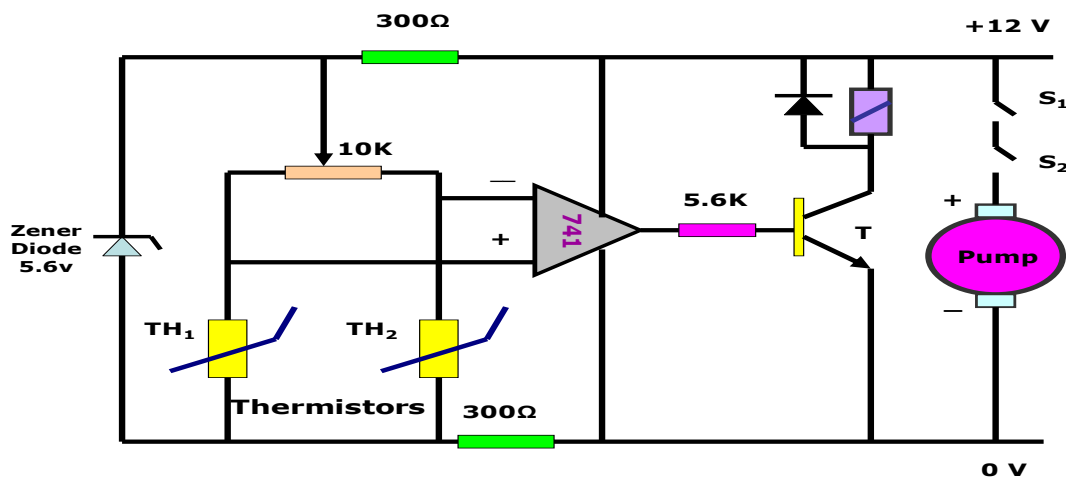

Control System of the Water Pump

Fig.(8) Control system of the water pump

2.7 Electrical Power Supplies:

In order to use the instrument in a far place of the electrical power supplies, a 12v battery is used to supply electrical power to operate all the control devices. The solar energy is used to charge the battery continuously using solar cells. The electrical circuits are connected in Fig.(9).

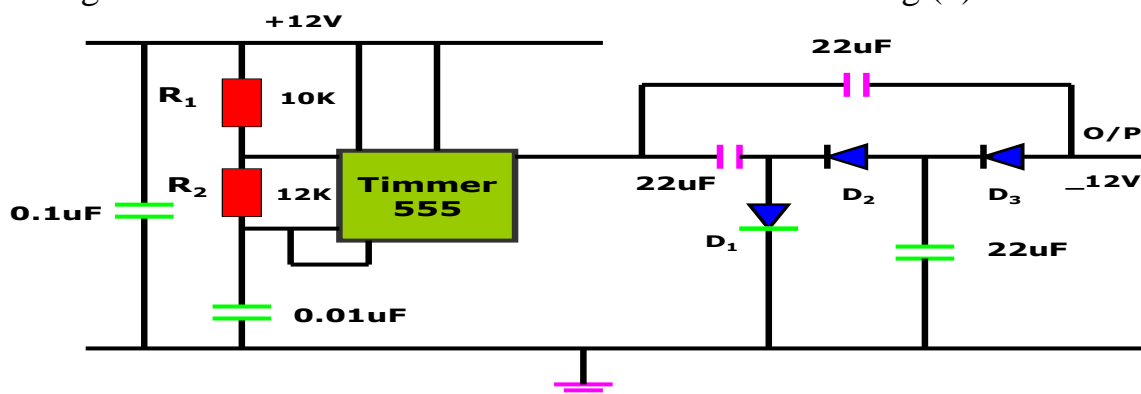

Conversion circuit of +12v to -12v

Fig.(9) Conversion Circuits

The battery voltage is converted into the required voltages and to be able to separate the electrical power supply in the sun reset automatically. Also a solar switch is designed operated by sun light to connect the battery to the control system and separate it in the sun reset.

A photo resistor is sensitive to sun light used and connected to the circuit as shown in Fig.(10). [7]

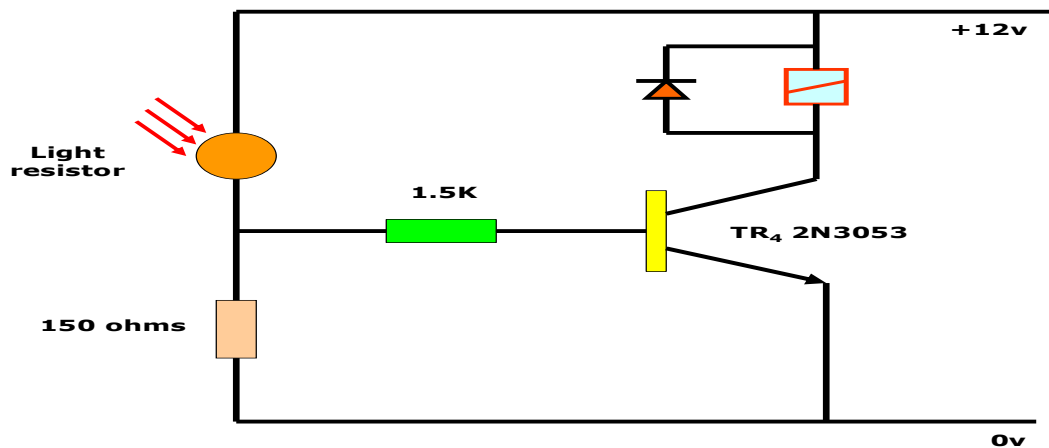
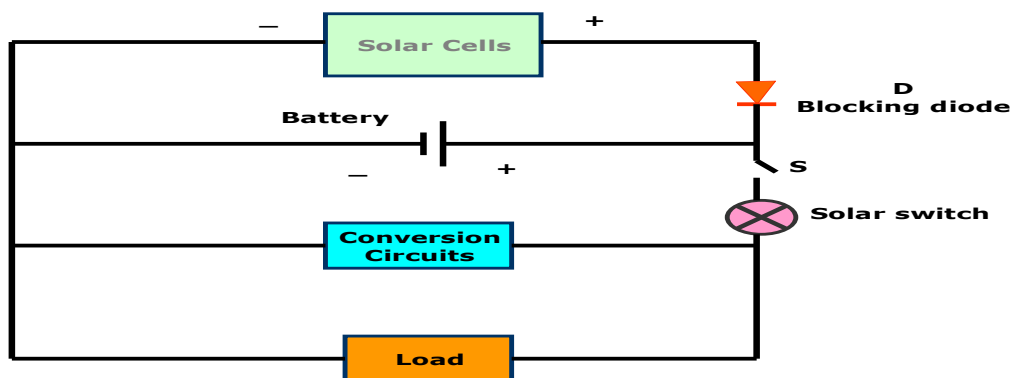

Fig.(10) Solar Switch

The solar cells are placed on a rotated iron frame tilted by 30 with the horizontal and mechanically connected with the solar system for tracking the sun light to increase its efficiency. It is connected electrically to the control system as shown in Fig.(11) below.



Connection of Solar Cells to the Control System

Fig.(11) Connection of Solar Cells

There are two diodes to prevent the flow of current from the battery to the solar cells during night or when the sky clouded.

A number of solar cells are arranged to be charged by 1.6A and 13.6v depending on the sun light falling on ground and the amount of consumed energy by the control system.

Total consumed electrical power of all devices = 33 A.h/day.

The average falling sun rays on the raw surface at Baghdad=517 C°/cm²/day.

The average external power in the raw = 9.7 A.h/day.

Number of required raws to charge the system = $33/9.7$
= 3.4

Therefore, at least four rows needed to charge the system.[6]

2.8 The Mechanical System:

This system is designed to transfer the electrical motor movement to the solar system which operates to reduce the speed and increase the required torque.

This mechanical system shown in Fig.(12) below.

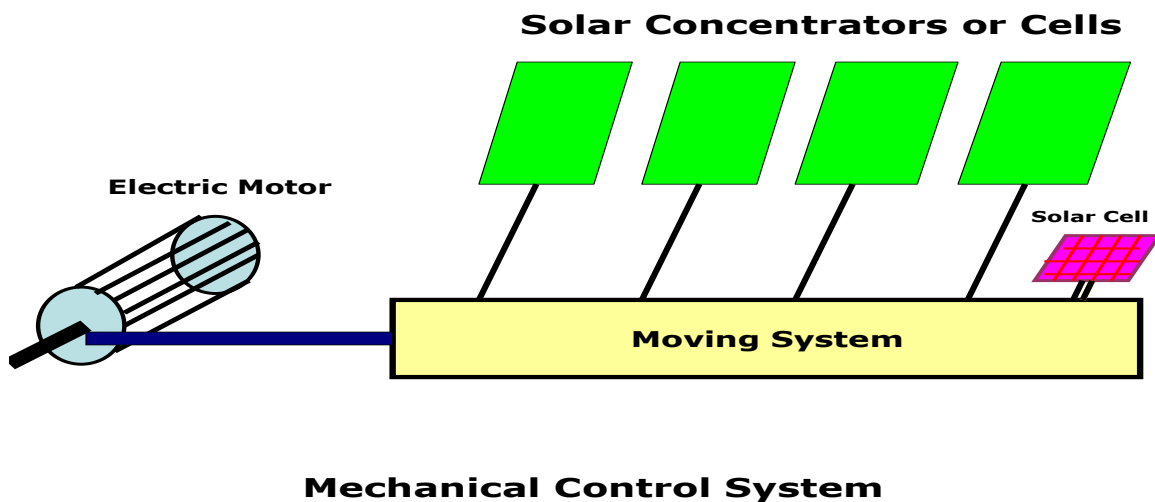

Fig.(12) The mechanical Control System.

This system consists of two metallic axis hold the solar concentrator from both sides and fixed on ground via ball bearings to reduce the friction, and on the lower axis two gears for each concentrator are fixed.

Each neighbored concentrators are connected by a metallic chain.

This solar system connected to the motor by a small pulley fixed on the motor axis which works according to the error signal comes from the control system.

The required torque to move the solar device and the power consumed by the motor is calculated as follows: [8]

3. PRACTICAL CALCULATIONS:

The required torque to move the solar device from stationary is calculated practically by use a force on the system rotating axis and equal to 4.8 N.m.

$$\text{Reduction Ratio} = \text{solar system rotating speed} / \text{motor rotating speed} = 1/2$$

The torque required to be generated by the motor is given by the following equation:

$$\frac{\text{Rotating torque required to move solar system } T_2}{\text{Required torque output of motor}} = \frac{\text{Motor rotating speed}}{T_1 \text{ Solar system rotating speed}}$$

$T_1 = 2.4 \text{ N.m.}$

The output torque of the motor related to the motor output power by:

The power = $T_1 U_1 \cdot 2\pi$, where: U_1 is the motor speed= 45 r.p.m.

The power = $2.4 (45/60) \cdot 2\pi$
 = 11.9 watts.

By adding (5) watts to result to compensate the losses of dust , therefore the power required to be generated = 16.4 watts.

4. FPGA SOLAR TRACKING TECHNIQUE:

A part of the work in this research is using a programmable FPGA chip. The design combines a processor with a two-axis motor tracking controller to integrate peripherals such as microprocessor, memory, and I/O into one Altera FPGA based on system-on-a-programmable-chip concepts. This integration accelerates development while maintaining design flexibility , reduces the circuit board costs with a single-chip solution, and simplifies product testing. Fig.(13) shows a solar tracker control block diagram. [9]

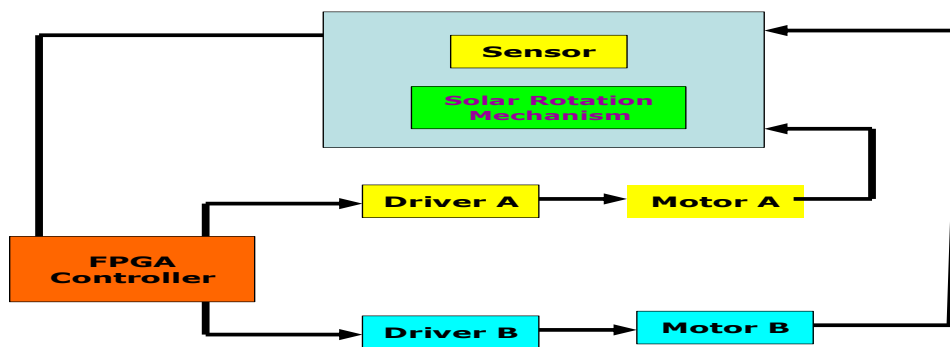

Solar Tracking using FPGA Controller

Fig.(13) a Solar Tracking using FPGA Controller

4.1 Design Architecture:

As shown in Fig.(14) the processor is the control center and integrates our two-axis chip. The system determines which data fed back to the FPGA using a photography sensor. It conducts the tracking control rule operation to calculate the angle required by the motor and adjusts motor's current angle. It also moves the solar panel to achieve optimal power. [9]

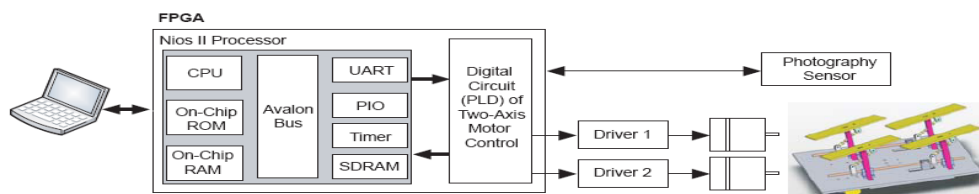

System Architecture

Fig.(14) FPGA Design Architecture

5. THE PRACTICAL RESULTS:

The device can be tested continuously , it tracks the sun light automatically without external electrical power supply.

- 1.The system response during the sun tracking for 15 minutes for two different time intervals on day. First at 11 o'clock morning and the second at 2 o'clock afternoon. It is realized that the system tracks the sun every (3-4) minutes in average. In other words when the sun deviation (0.5-1) degree the system response is 0.5 second. The cause of difference in response for both intervals is that the solar collectors at 11 o'clock are horizontal and more stable than other places.
- 2.the system response is tested for different values of input signal θ_i . it was found that the system response non linear when the input signal increased and this affected by relays and the non perfect connection of the pulleys and chains in the mechanical system.

6. DISCUSSION AND CONCLUSIONS:

The renewable energy sources in far areas are always required, particularly if the cost is acceptable to be used in the civilian and army purposes with the insurance of continuous supply.

The solar energy in our country is very important , however, the average of falling energy is 0.6 kw/m^2 . To get the advantage of this energy , a solar collectors with different designs are used to convert the solar energy into other types of energy.

From the practical experiments it is found that the plane collectors are un efficient with limited temperature degrees.

For this reason we use solar concentrators supplied by automatic tracking system, which increases the system efficiency. The feature of this system is that most of its components are available in our markets. Also there is rechargeable battery (12v) to supply the electronic circuits. This battery is charged automatically by sun light through the concentrators.

It is found that the error between tracking intervals is equal to 0.5 degree, this is acceptable because of the existence of many movable parts in the system and the existence of dust on all movable parts of the system which increases the friction force.

The compensation of power losses is treated by adding 5 watts to the output torque of the electric motor.

It was found that the system operation of control and efficiency view is good according to the designed calculations.

As FPGAs have evolved in recent years, a single FPGA can accommodate more logic circuits. Building of whole digital electronic circuit on a single chip provides a big edge in speed and power consumption, making system-on-a-programmable-chip designs gradually become the design tendency. As an emerging systematic design technology, can incorporate the hardware

system(including processor, memory, peripheral interface circuit, and user logic circuit) and software design on a single programmable chip.

7. REFERENCES:

- [1] H.Messel, S.T.Buttler, Solar Energy, Pergaman Press, book 1975.
- [2] R.H.B.Exell, Experiments on prototypes solar powered, Refrigerator for remote areas, Proceeding of ISEC Conference of solar energy, New delhi Jan..1978.
- [3] A.C.Johnson, Commercialization of solar heating and cooling, Joint conference, American, ISEC and solar energy society of Canada Inc, August 15-20 1976, Winnipeg.
- [4] Lucas Service Commercial Catalog for Module E1215, Windmill Road, Haddenham, England.
- [5] Statistical Report, Solar Intensity in Baghdad, Metrological Office, Baghdad-Iraq.
- [6] K.C.Gupta, R.K.Mirakhur, A.P.Sathe, A Simple Solar Tracking System, ISCW extended Abstracts, New Delhi 16-21 Jan. 1978.
- [7] Marcell Dagher, Solar Energy- Schumas Series, Beruit 1970.
- [8] Raad Abdul-Mageed, Design and Construction of multistage control and tracking solar energy system, University of Technology, 1979.
- [9] Intelligent Solar Tracking Control System Implemented on an FPGA. Institute of Electrical Engineering, Yuan Ze University, Jan.2005.

تطوير منظومة التعقيب للمركزات الشمسية ذات المراحل المتعددة

د. كريم كاظم جاسم

الجامعة التكنولوجية

مركز بحوث الطاقة والوقود

الخلاصة:

يتضمن البحث تطوير منظومة التعقيب الذاتية لوحداث من مصفوفات المركزات الشمسية القابلة للتوسع وتتميز المنظومة باستخدامها الطاقة الناتجة من الخلايا الشمسية مباشرة في دائرة التعقيب. اي ان التغذية الكهربائية تكون ذاتية لذا يمكن استخدام هذا النوع في الاماكن الريفية والناحية من قطرنا. كما تضمن البحث امكانية تطوير العمل باستخدام تقنية متقدمة مبرمجة (FPGA) ، وذلك بتصميم برنامج للسيطرة على حركة المركزات الشمسية مما يزيد من دقة وكفاءة المنظومة المصممة وتقليل المفاقد وزيادة الطاقة المتولدة منها.