

An analytical study to reduce the effect of dust on the performance of solar panels using water system

Dr.Kareem K.Jasim, Dr.Abbas Z.Salman, Eng.Mahdi Sarhan

An analytical study to reduce the effect of dust on the performance of solar panels using water system

**Dr.Kareem K.Jasim Dr.Abbas Z.Salman
Eng.Mahdi Sarhan,**

Energy and Renewable Energy Technology Center,
University of Technology

ABSTRACT:

The aim of this work is to study the effect of dust on the performance and efficiency of solar cells . Two solar panels were used clean and dusty each consists of 12 solar cells. The remaining challenge is to find accost-effective way to apply these principles to construct a low-cost solar cell with high and stable efficiency.

Photovoltaic (PV) cells have social and commercial value only when they are used in a system to provide a service. This research has given a brief overview of the technical and economic considerations that allow the cells to provide such a service. An automatic closed water circuit was designed and implemented to clean and increase the efficiency of the solar panel.

1.INTRODUCTION:

Photovoltaic technology has a number of advantages over conventional methods of electricity generation. First, solar energy is the world's major renewable energy resource. Photovoltaic power can be generated from the sun any where in temperate or tropical locations and in urban or rural environments. As a fuel-free distributed resource, photovoltaics could, in long run, make a major contribution to national energy security and carbon dioxide abatement. Photovoltaic is uniquely scalable, the only energy source that can supply power on a scale of milliwatts to megawatts from an easily replicated modular technology with excellent economies of scale in manufacture. Typical crystalline silicon Photovoltaic cell generates about 1.5 peak watts

An analytical study to reduce the effect of dust on the performance of solar panels using water system

Dr.Kareem K.Jasim, Dr.Abbas Z.Salman, Eng.Mahdi Sarhan

(WP) of direct current (DC) power, a typical Photovoltaic module about 50 WP and the world's largest multimodule arrays generate upward of a megawatt apiece. Photovoltaic cells are made of thin films. They contain small amounts of non-toxic materials and when manufactured in volume, have modest embedded energy. They possess no moving parts, they don't need cooling water system and they are silent in operation. Photovoltaic systems are easy to use and long-live if properly maintained. [1]

Photovoltaic has three drawbacks.

- 1- The intermittence and seasonality of sunlight.
- 2- Photovoltaic systems are very costly.
- 3- Photovoltaic is one faced by many emergent technologies-ignorance. [1]

1.1. Crystalline Silicon Solar Cells:

The majority of solar cells fabricated to date have been based on silicon in monocrystalline or large grained polycrystalline form. There are two main reasons for this. The first reason is that silicon is an elemental semiconductor with good stability and a well-balanced set of electronic, physical and chemical properties, the same set of strengths that have made silicon the preferred material for microelectronics. The second reason why silicon cells have been so dominant is that the success of silicon in microelectronics has created an enormous industry where the economies of scale directly benefit the presently smaller photovoltaics industry. [2,3]

1.2. Electrical Connection of the Cells:

There are two basic connection methods: series connection in which the top contact of each cell is connected to the back contact of the next cell in the sequence and parallel connection in which all the top contacts are connected together as are all the bottom contacts. In addition connected in a series string to increase the voltage level and in parallel to increase the current level. See figure (1)(a, b). [2]

An analytical study to reduce the effect of dust on the performance of solar panels using water system

Dr.Kareem K.Jasim, Dr.Abbas Z.Salman, Eng.Mahdi Sarhan

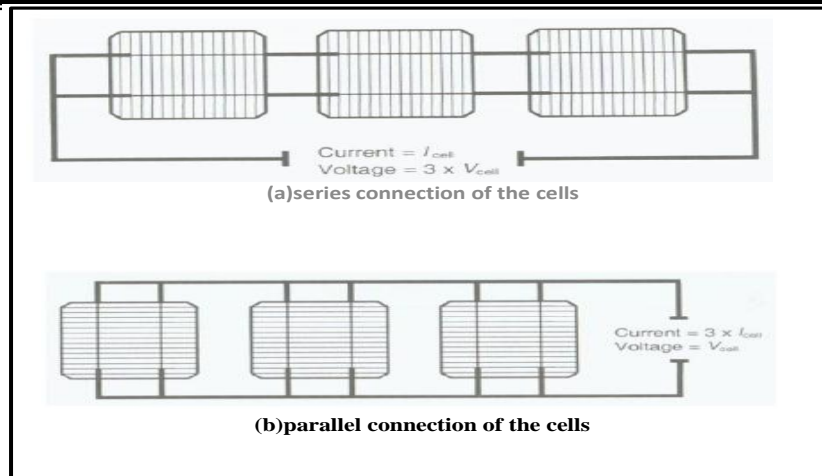
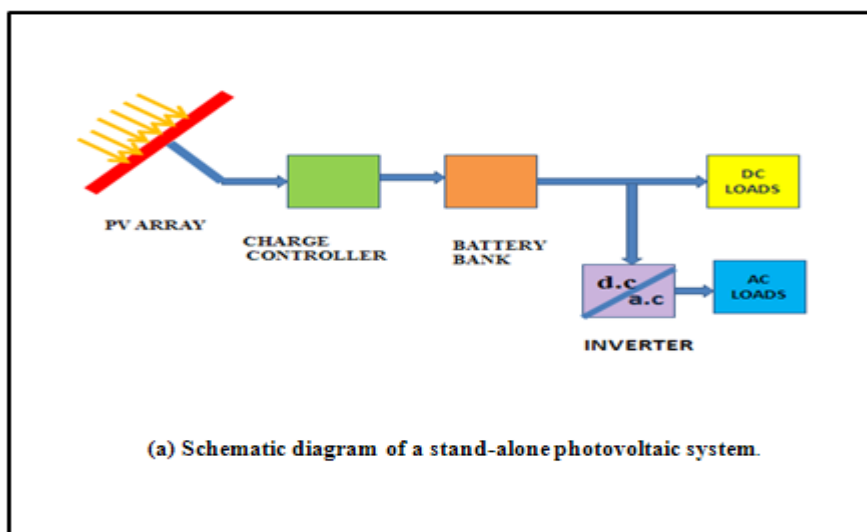

Fig.(1) Types of cell connections

1.3 Photovoltaic Systems;

There are two main system configurations- stand-alone and grid-connected. In the stand-alone system operates independently of any other power supply and it usually supplies electricity to a dedicated load or loads. It may include a storage facility (e.g. battery bank) to allow electricity to be provided during the night or at times of poor sunlight levels. By contrast the grid-connected PV system operates in parallel with the conventional electricity distribution system. It can be used to feed electricity into the grid distribution system or to power loads which can also be fed from the grid. Fig.(2) shows different photovoltaics systems.[3, 4]



An analytical study to reduce the effect of dust on the performance of solar panels using water system

Dr.Kareem K.Jasim, Dr.Abbas Z.Salman, Eng.Mahdi Sarhan

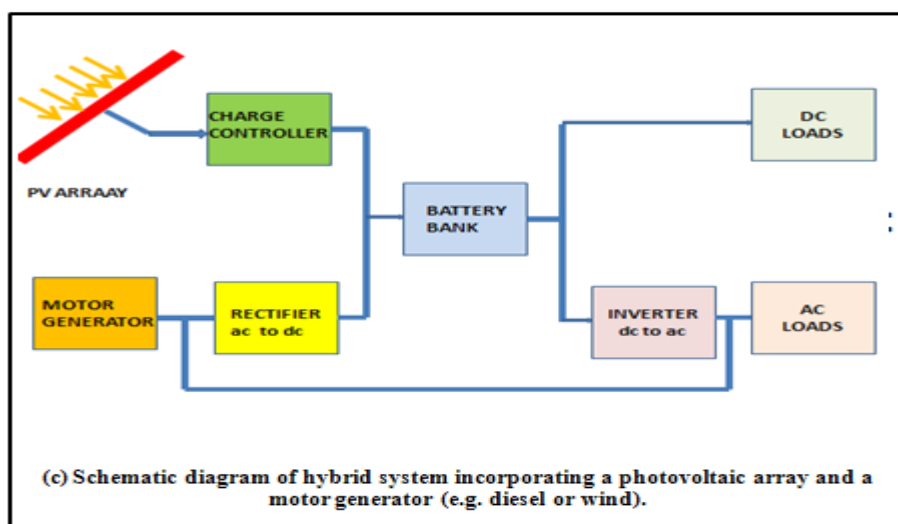
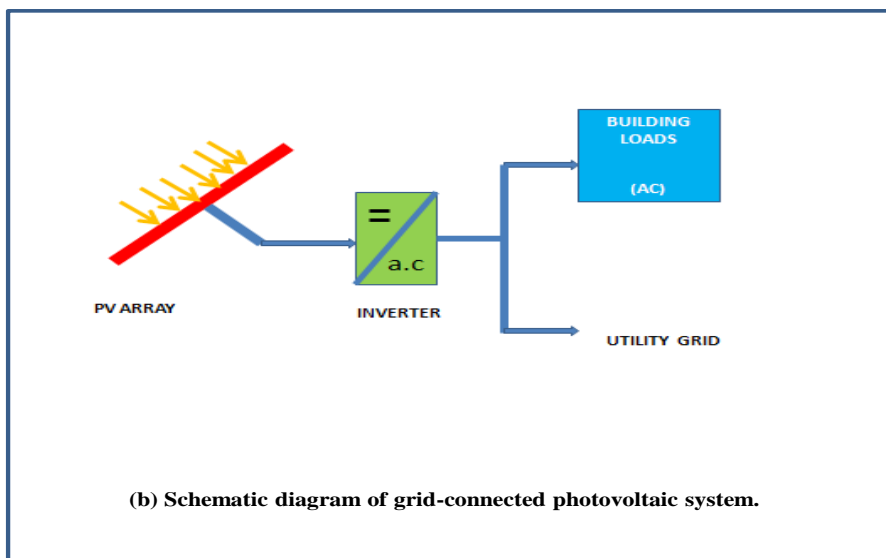

Fig.(2) Different types of photovoltaic systems

3.AIM OF WORK:

The aim of work is to study the effect of dust and dirt on the efficiency and performance of solar cells. The efficiency of solar energy deployment and performance of a basin-type still is considered. The effect of sun tracking on the design and operating factors such as the ambient temperature, basin temperature, brine temperature, cover temperature, and solar radiation (irradiance/intensity) and how they influence productivity were examined and analysed. Basin and brine temperatures have positive effects on the productivity, but the effect of glass cover temperature

An analytical study to reduce the effect of dust on the performance of solar panels using water system

Dr.Kareem K.Jasim, Dr.Abbas Z.Salman, Eng.Mahdi Sarhan

was not so obvious. It was evident from the results that the solar intensity impacted on the productivity directly and positively. A sun tracking mechanism was explored to determine how this affects the performance of the still.

2.EXPERIMENTAL WORK:

The experimental part of this work consists of:

- solar simulator calibration
- Monocrystalline photovoltaic module
- instruments to measure the temperature
- instrument to measure the current and voltage

2.1 Monocrystalline photovoltaic module:

The PV module was disconnected from the battery and placed under the solar simulator. The irradiance was varied by varying the electrical voltage to the solar simulator lamps and output (voltage and current) of the module. See figure (3) [5]

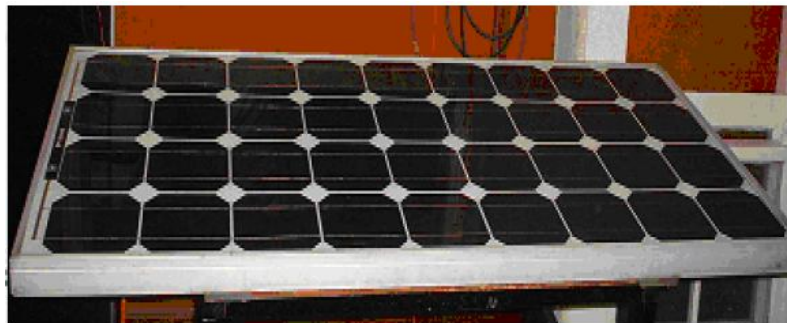

Figure (3) monocrystalline photovoltaic module.

Normal peak power (**P_{max}**) ---- 225.00 watt

Peak power voltage (**V_{mp}**) --- 27.00 Volt

Peak power current (**I_{mp}**) --- 7.0 Ampere

Short circuit current (**I_{sc}**) --- 7.5 Ampere

Open circuit voltage (**V_{oc}**) --- 29.03 volt

Minimum power (**P_{min}**) --- 220.00 watt

Power specifications measured at standard test conditions, insolation of 1000w/m², am 1.5, 25 °c cell temperature.

From this information it found the fill factor (F) was

Found as:

$$F = \frac{V_{mp} * I_{mp}}{I_{sc} * V_{oc}}$$

$$F = 0.7713$$

An analytical study to reduce the effect of dust on the performance of solar panels using water system

Dr.Kareem K.Jasim, Dr.Abbas Z.Salman, Eng.Mahdi Sarhan

$$\text{Power } P = I_{sc} * V_{oc} * F$$

Instruments to measure open circuit voltage and short circuit current

There after, the open circuit voltage and short circuit current could be measured. See figure (4). [6,7]

2.2 The water closed system designed:

The block diagram of the water system used in this research is shown below in Figure(4) .The system consists of two water tanks and three motors to keep the water circulating through the system.

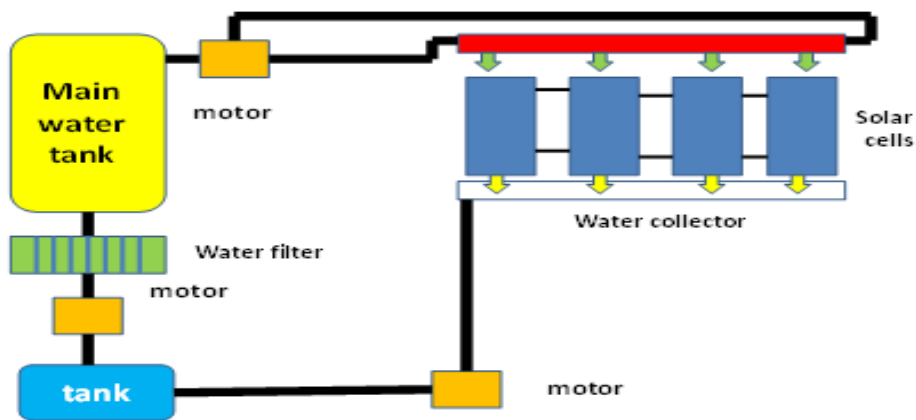

Figure(4) The block diagram of the water system used

The complete system designed and implemented with nozzles is shown in Figure (5).

Figure(6) shows the water system designed to clean the solar panel with water tube instead of nozzles for comparison.



Figure(5) Using nozzles to clean the solar panels

An analytical study to reduce the effect of dust on the performance of solar panels using water system

Dr.Kareem K.Jasim, Dr.Abbas Z.Salman, Eng.Mahdi Sarhan



Figure(6) Using water pipe to clean the solar panels

Control system consists of two electronic timers to control the falling and stopping the water and collecting the dirty water by a metallic tray to pass through the filter as shown I Fig.(7).

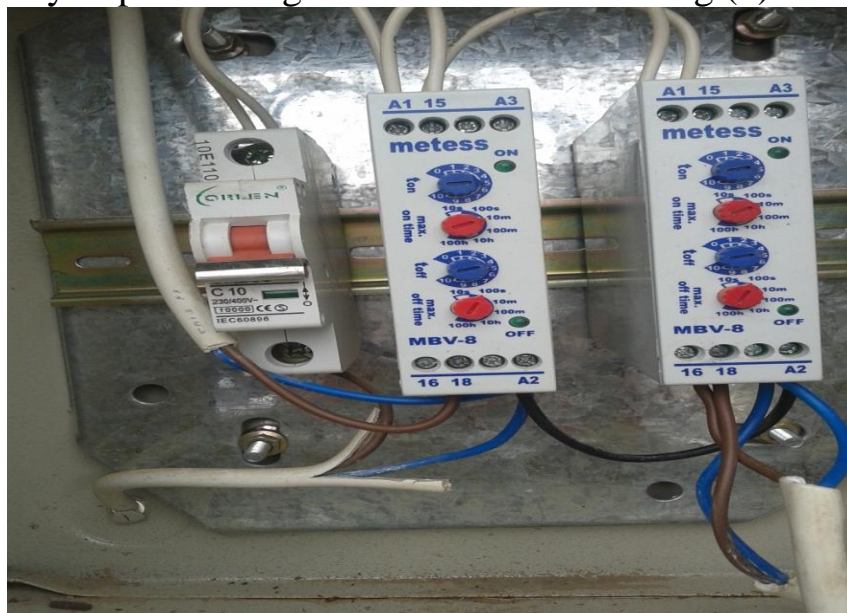

Figure(7) Control timing system

3.RESULTS:

Results of the experiments are presented in the form of graphs and tables, 12 clean solar cells (224w) and 12 dusty solar cells(224w) were used to show the effect of dust on the performance and efficiency of solar cells. Fig.(8) shows the effect of irradiance on the characteristics of solar panel for different irradiance levels. The output of the panel increases as irradiance increases.

An analytical study to reduce the effect of dust on the performance of solar panels using water system

Dr.Kareem K.Jasim, Dr.Abbas Z.Salman, Eng.Mahdi Sarhan

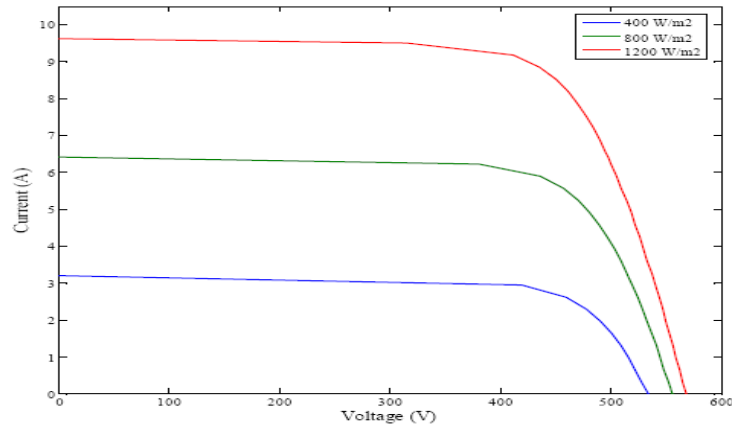

Fig.(8)The effect of irradiance on the I-V characteristics of a PV module

The effect of temperature on the characteristics of the photovoltaic module is shown in Fig.(9) however as the temperature increases the output voltages decreases.

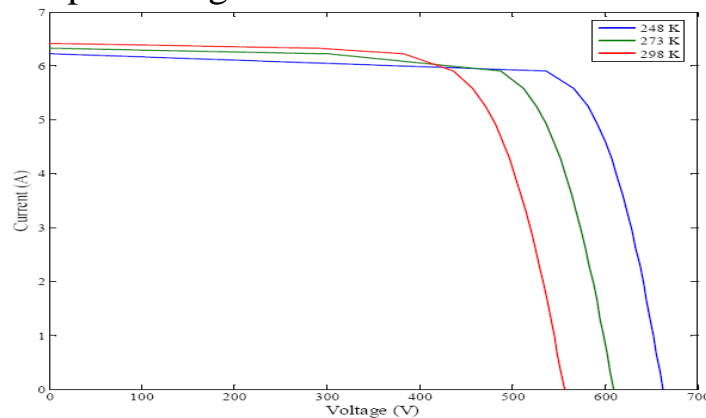

Fig.(9)The effect of temperature on the I-V characteristics of a PV module with irradiance of 800 w/m²

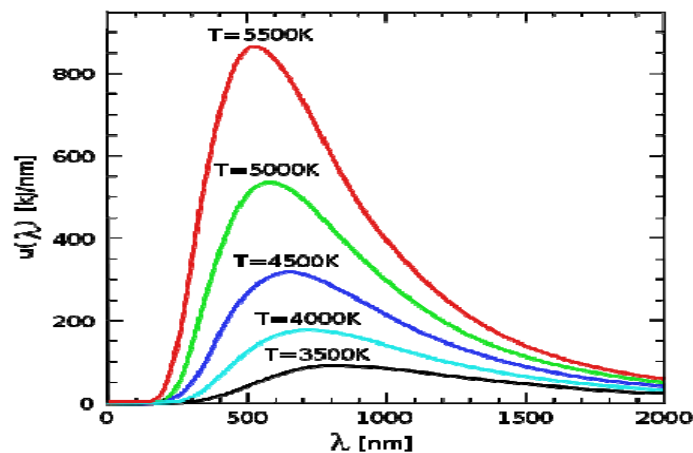

Fig.(10)Spectral irradiance for different black body temperature

An analytical study to reduce the effect of dust on the performance of solar panels using water system

Dr.Kareem K.Jasim, Dr.Abbas Z.Salman, Eng.Mahdi Sarhan

Fig.(10) shows the spectral irradiance for different temperatures. The relationship between voltage and current and the power-voltage relation of a single solar module are illustrated in Fig.(11) and Fig.(12) respectively.

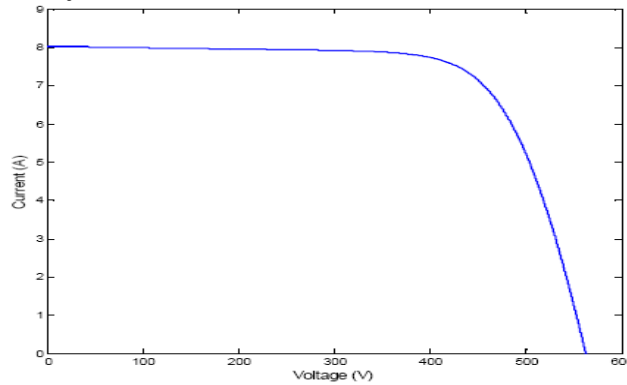

Fig.(11)I-V characteristics of the solar cells

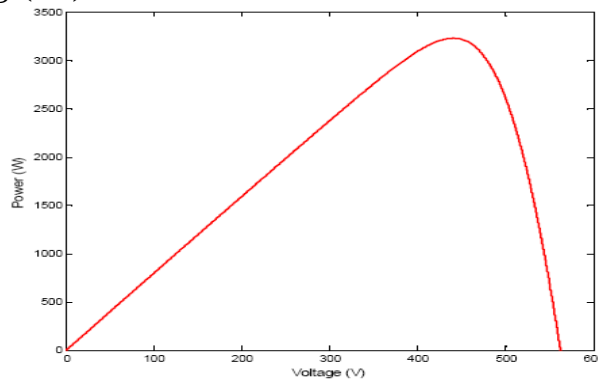

Fig.(12)P-V characteristics of the solar cells used

Fig.(13) shows the effect of irradiance and ambient temperature on the calculated temperature of the module used.

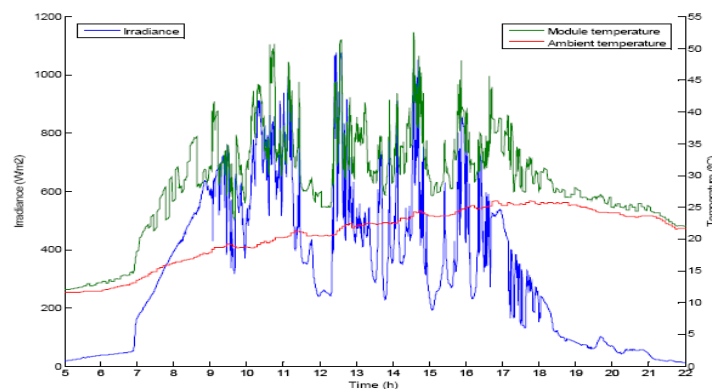

Fig.(13)The effect of irradiance and ambient temperature on the calculated module temperature.

An analytical study to reduce the effect of dust on the performance of solar panels using water system

Dr.Kareem K.Jasim, Dr.Abbas Z.Salman, Eng.Mahdi Sarhan

The relationship between the voltage generated and generated current by the clean solar cells for different seasons are shown in Fig.(14) . As shown in summer the solar rays density is greater than other seasons leading to higher power generation and this is proved in Fig.(15).

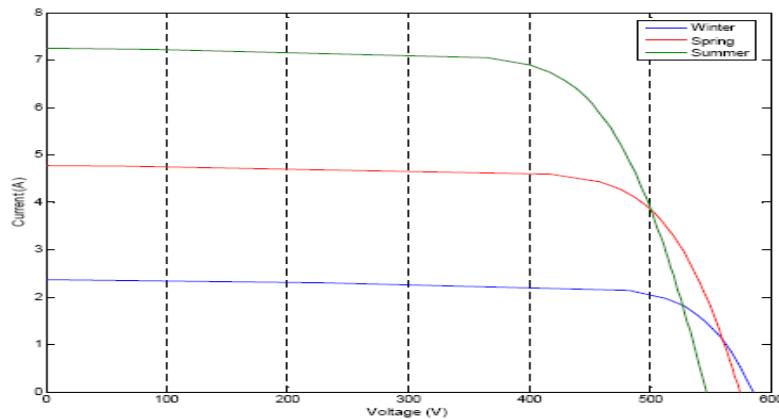

Fig.(14)The I-V performance characteristics of the clean solar cells in winter, spring and summer

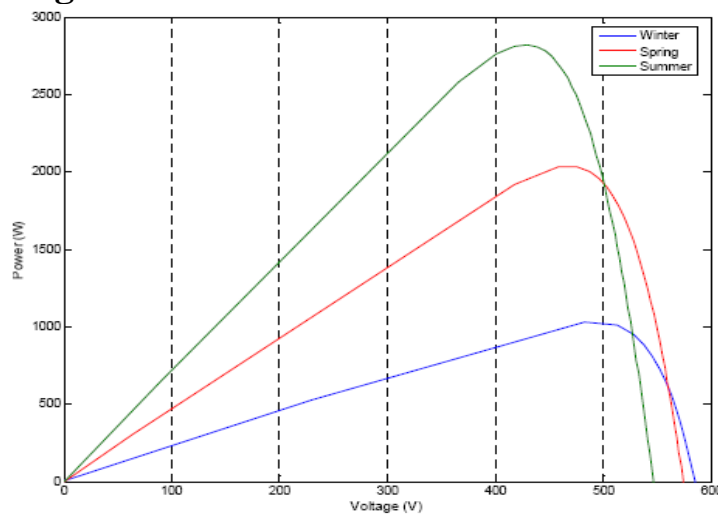

Fig.(15) The P-V performance characteristics of the clean solar cells during winter, spring and summer.

An analytical study to reduce the effect of dust on the performance of solar panels using water system

Dr.Kareem K.Jasim, Dr.Abbas Z.Salman, Eng.Mahdi Sarhan

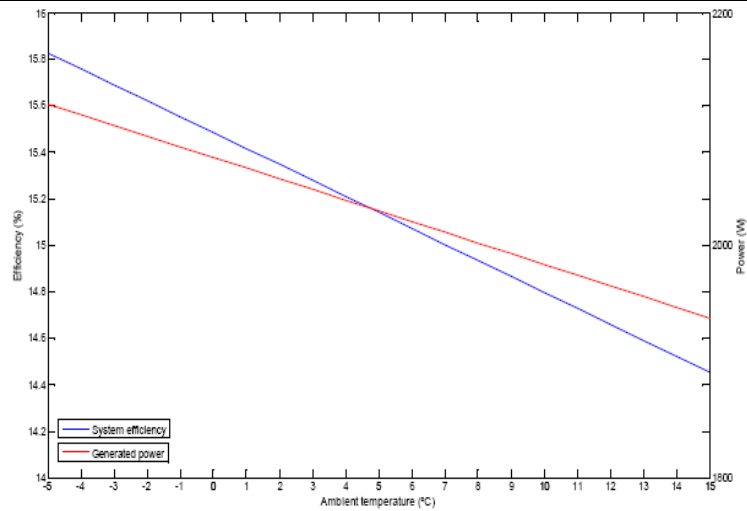

Fig.(16) The efficiency and the power generated of the system

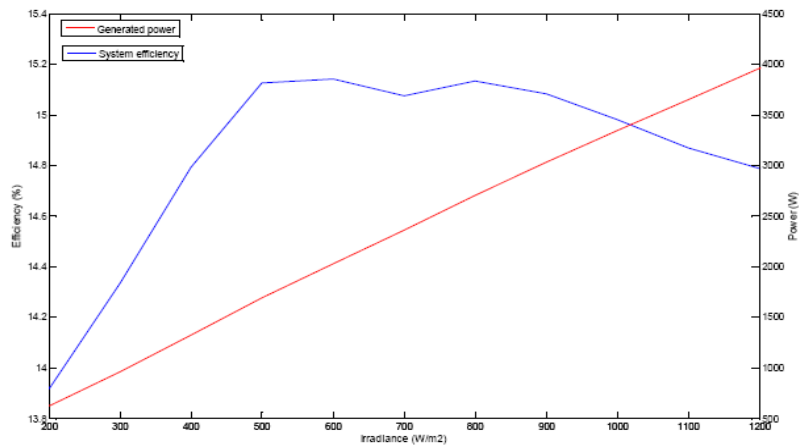

Fig.(17)The efficiency and power generated against the irradiance

The efficiency and power generated by the solar module used in this work and the efficiency and the power generated against the irradiance are illustrated in Fig.(16) and Fig.(17) respectively. It is obvious that the efficiency of the system decreases as the temperature increases. The power generated increases with the irradiance.

An analytical study to reduce the effect of dust on the performance of solar panels using water system

Dr.Kareem K.Jasim, Dr.Abbas Z.Salman, Eng.Mahdi Sarhan

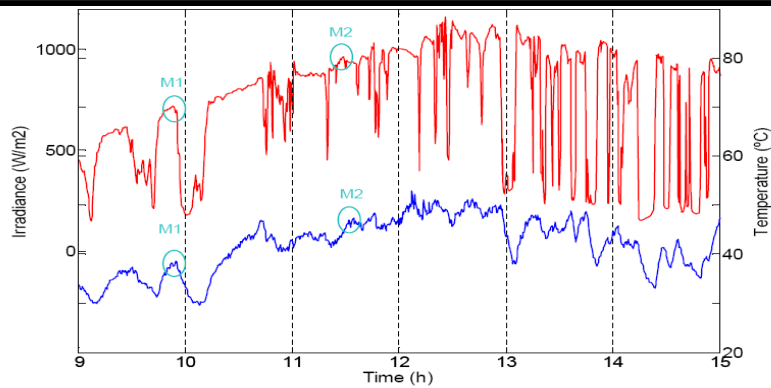

Fig.(18)Irradiance and module temperature measured in April 2012

Fig.(18) above shows the irradiance and the temperature of the solar module used against time during April of 2012. It illustrates that the irradiance is highest in the mid of the day. Fig.(19) shows the measurements of irradiance and temperature during Sep. 2011.

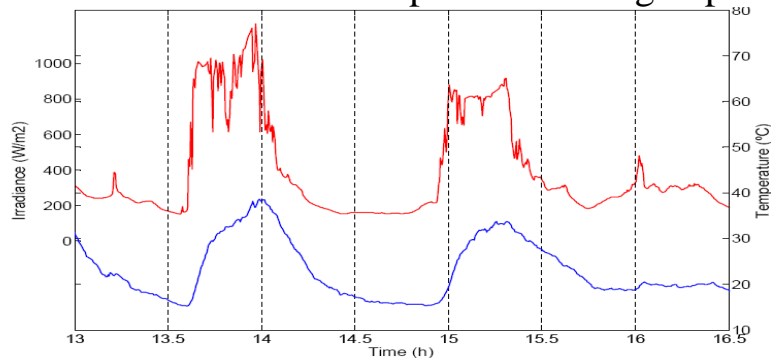

Fig.(19)Irradiance and module temperature measured in September 2011

The current-voltage characteristics of both clean and dusty solar cells measured and calculated are shown in Fig.(20). Fig.(21) shows the measured and calculated power-voltage relation.

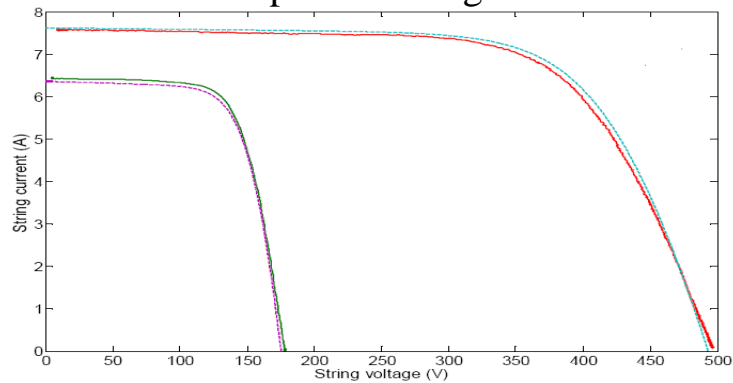

Fig.(20)The I-V characteristics of the clean and dusty solar cells

An analytical study to reduce the effect of dust on the performance of solar panels using water system

Dr.Kareem K.Jasim, Dr.Abbas Z.Salman, Eng.Mahdi Sarhan

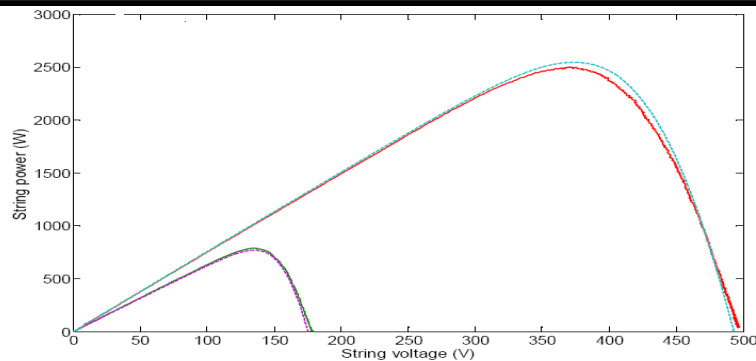

Fig.(21)The P-V characteristics of the clean and dusty solar cells

The relationship between the voltage-current and the power-voltage of the solar system tested with more cells for both dirty and clean cells are shown in Fig.(20) and Fig.(21) above. It is obvious that as the number of solar cells increases the output power increases. Fig.(22) and Fig.(23) shows the current-voltage and the power voltage characteristics of dusty and clean solar modules used during Sept. 2011.

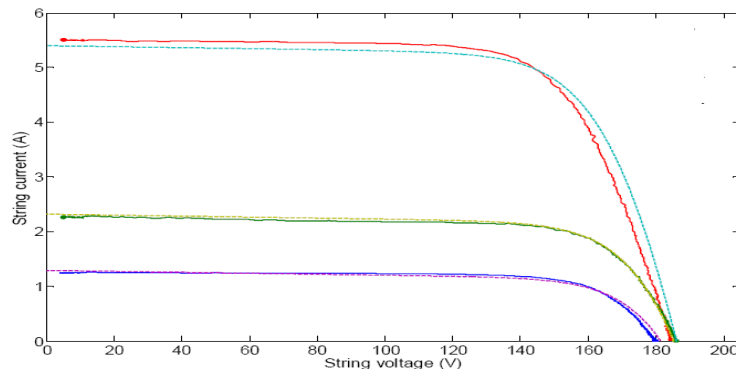

Fig.(22)The I-V characteristics of the clean and dusty solar cells

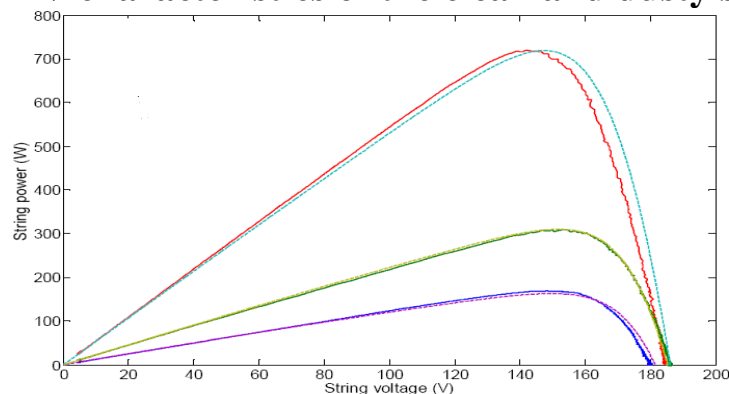

Fig.(23) The P-V characteristics of the clean and dusty solar cells in September 2011.

An analytical study to reduce the effect of dust on the performance of solar panels using water system

Dr.Kareem K.Jasim, Dr.Abbas Z.Salman, Eng.Mahdi Sarhan

4.CONCLUSION:

A PV module is an electricity generator and requires additional equipment if it is to provide a useful service.

A PV is in the midst of benign cycles where increased sales lead to larger scale production, which leads to lower costs which leads to increased sales. The targets for low-cost production can be met almost entirely by this increasing scale of production, which follows from increased sales. Technological improvements in the solar cells are an additional bonus, although much remains to be done in bringing laboratory-scale performance to commercial production.

Photovoltaics have the potential to become a major electricity generation technology in the next few decades. It will fulfill this potential only if it is recognized that technical success with cells or modules is a necessary but not sufficient criterion for commercial success. It is the PV system that provides the services for which users will pay and these must be designed and implemented to the same level of quality and performance as the modules themselves.

The experiments showed that the power output exhibited a slight decrease as the ΔT value increased. That means there was significant effect of the increasing in the surface temperature on the power output.

There is relationship between temperature ΔT irradiance G. Therefore in Iraq in which the air temperature reaches 45 °c in summer would result in a maximum surface temperature 95 °c . This increase in temperature together with the lower intensities of irradiance experienced in practice would result in the module tested delivering 66% of its rated power when used in Iraq.

Other hand the measurements showed that the performance and efficiency of the clean solar cells are better than the dusty solar cells, in other words the dust and dirt decreases the efficiency of solar systems.

An analytical study to reduce the effect of dust on the performance of solar panels using water system

Dr.Kareem K.Jasim, Dr.Abbas Z.Salman, Eng.Mahdi Sarhan

5.REFERENCES:

- [1] Aberle A. G., Heiser G. and Green M. A. (1994), 'Two-dimensional minority carrier flow in high efficiency silicon solar cells at short-circuit, open-circuit and maximum power point operating conditions', Solar Energy Mater. Solar Cells 34,149-160.
- [2] Brandhorst H. W. and Bernatowicz D. T. (1980), 'Space solar cells-high efficiency and radiation damage', Conf. Record 14th. IEEE Photovoltaic Specialists Conf., San Diego, IEEE Press, Piscataway, 667-671.
- [3] World Meteorological Organization Guide to Meteorological Instruments and Methods of Observation. WMO-No 8, 2008.
- [4] Young H, D, & Freedman. R.A. Sears and Zemansky's university physics: with modern physics 12th ed. USA 2008. Pearson Addison-Wesley p.1551.
- [5] Endros A. L., Einzinger R. and Martinelli, G.(1997), 'Tri-silicon: a novel substrate for thin wafer solar cells', Proc. 14th. European Photovoltaic Solar Energy Conf., Barcelona, H. S. Stephens & Associates, Bedford, 112-114.
- [6] Villalva M.G. Gazoli. J.R. & Comprehensive approach to modeling and simulation of photovoltaics arrays. IEEE transaction on power electronics vol.24 no.5 2009 pp.1198-1208.
- [7] Green M. A. (1995), Silicon Solar Cells: Advanced Principles & Practice, Centre for Photovoltaic Devices and Systems, University of New South Wales, Sydney.
- [8] Green M.A. and Hansen J. (1998), Catalogue of Photovoltaic Drawings, Photovoltaics Special Research Centre, University of New South Wales, Sydney.
- [9] Sera. D. Teodorescu. R. and Rodriguez. P. PV panel model based on datasheet values. IEEE Xplore. 2007.
- [10] Skoplaki. E. Boudouvis. A.G. and Palyvos. J.A. A simple correlation for the operating temperature of photovoltaic modules of arbitrary mounting. Solar energy materials & solar cells. 92.2008 pp.1393-1402.
- [11] Hovel H. J. (1975), 'Solar cells', Ch. 2 in Semiconductors and Semimetals, Vol. 11, Willardson R. K. and Beer A. C., eds., Academic Press, New York.
- [12] Skoplaki E. Palyvos. J. A. On the temperature dependence of photovoltaic module electrical performance: A review of efficiency power correlation. Elsevier. 2008.
- [13] Skopaki E. and Palyvos. J. A. Operating temperature of photovoltaic modules: A survey of pertinent correlations. Renewable Energy. 34.2009. pp.23-29.

الخلاصة:

يتضمن البحث دراسة انواع الخلايا الشمسية وكفاءتها و كيفية انتاج الطاقة الكهربائية من الخلايا الشمسية وطرق ربطها. كذلك يتضمن دراسة عمل وخصائص الخلايا الشمسية ذات القدرة الواطئة والكفاءة العالية المستقرة فى درجات حرارة مختلفة. وقد استخدم فى هذا البحث مجموعتين من الخلايا الشمسية احدهما نظيفة والاخرى متسخة كل منهما مكون من 12 خلية شمسية لدراسة تاثير الغبار على اداء المنظومات الشمسية وتاثير المياه على زيادة كفاءة الخلايا الشمسية وتبريدها. كما تم التطرق الى المنظومات الشمسية المختلفة وتطبيقاتها. هذا البحث يقدم الاعتبارات الاقتصادية والتقنية للخلايا الشمسية التى تسمح بتزويد الطاقة الكهربائية. كما صممت منظومة مياه اتوماتيكية لتنظيف الخلايا الشمسية من اجل زيادة كفاءتها وتحسين اداءها.